





A x 2	B x 2	C x 1	D x 1	E x 2	F x 2
M8	M6	M6	3mm		
					
G x 4	H x 16	i x 8	M x 1 4mm		
					
			N x 1		





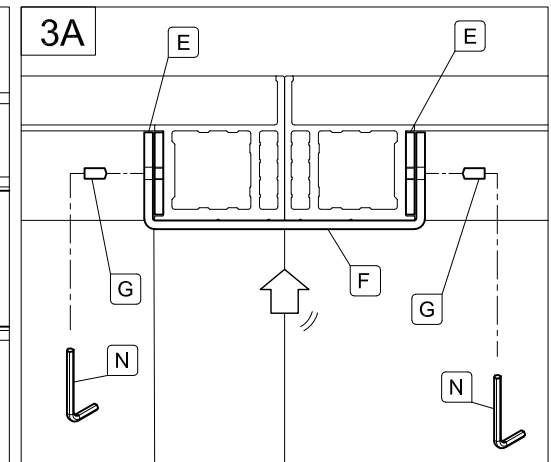
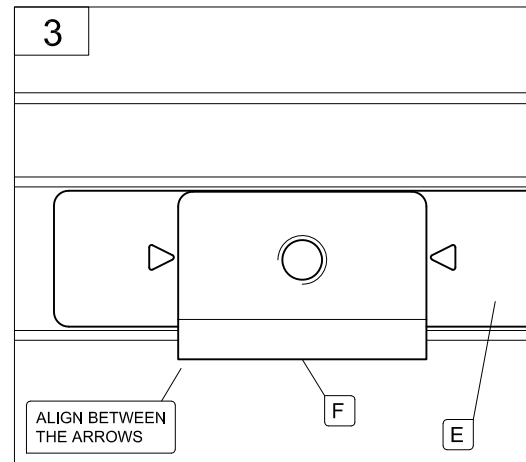
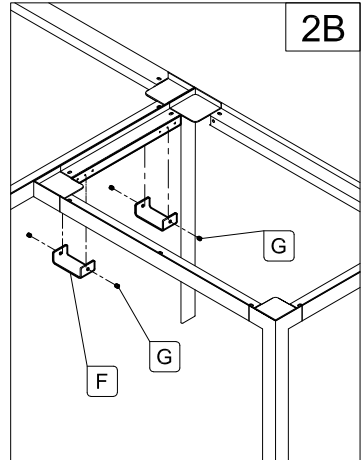
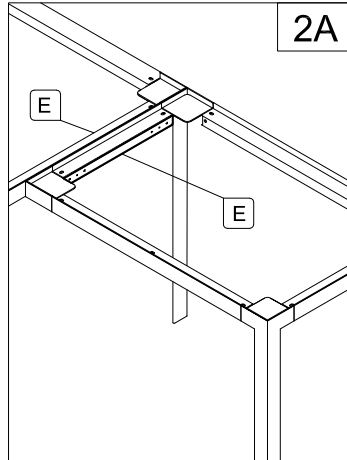
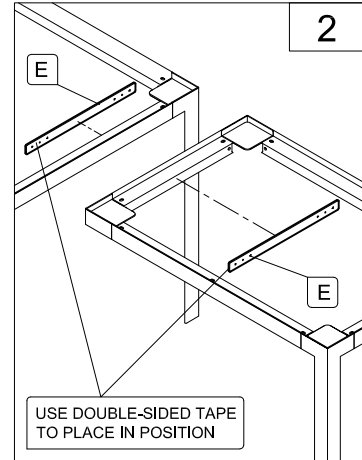
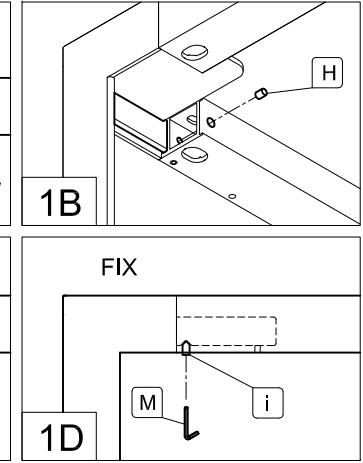
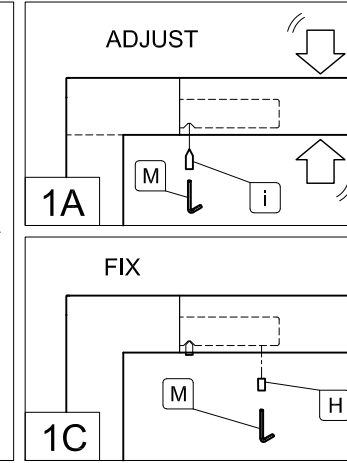
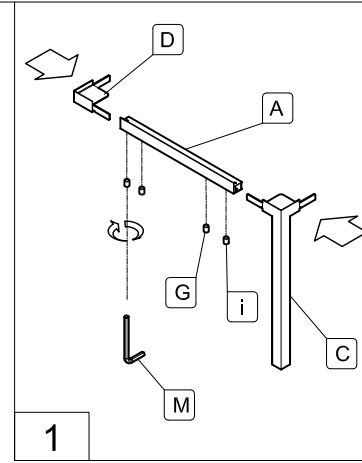
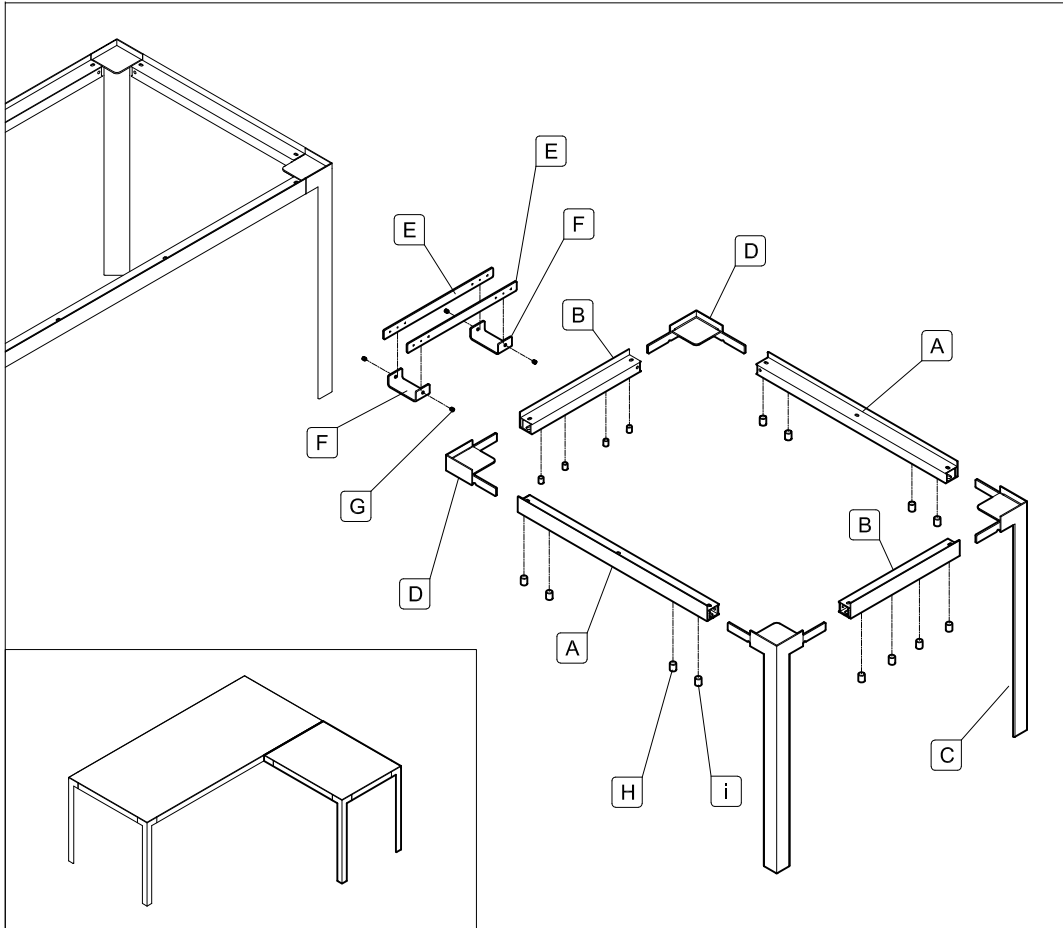
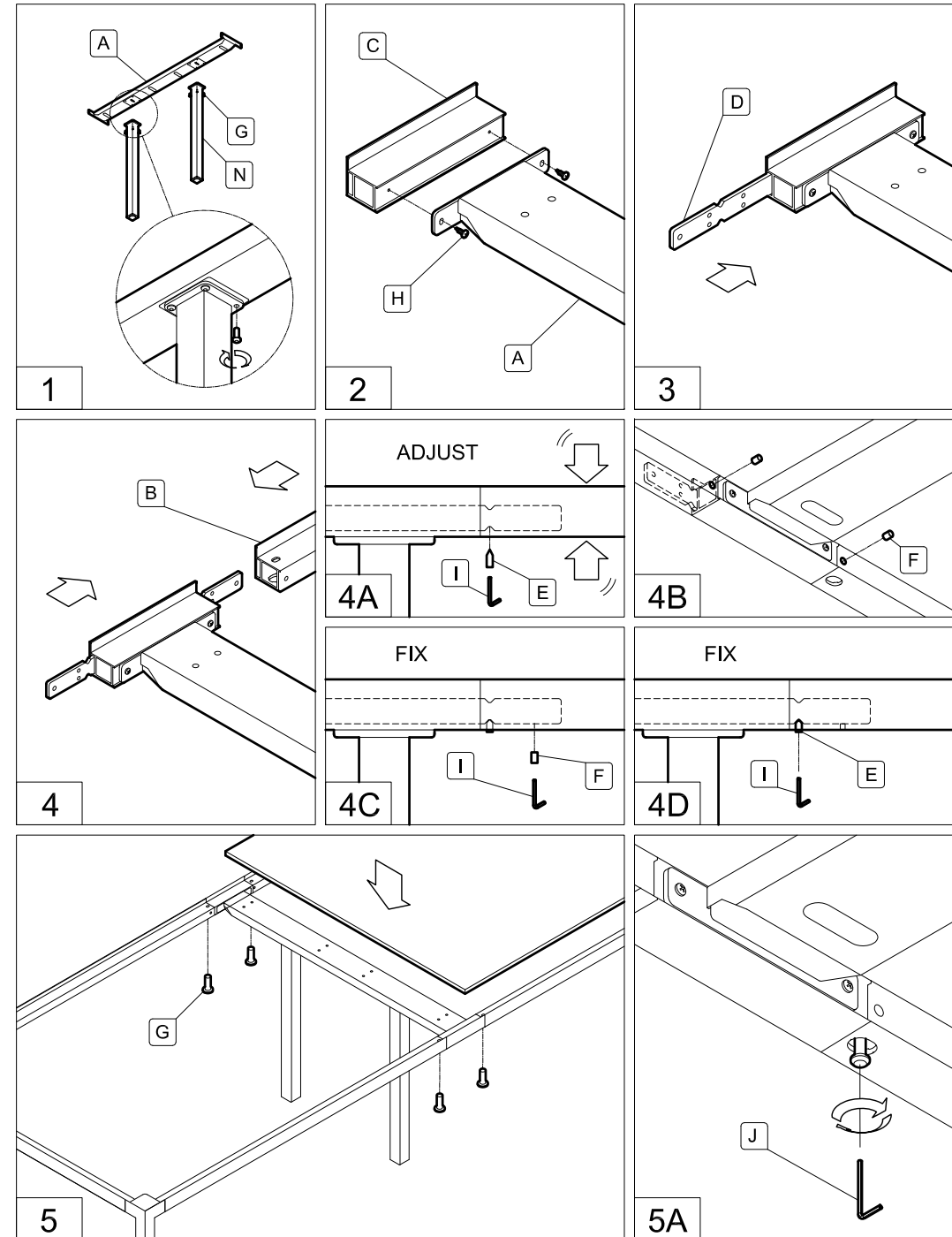
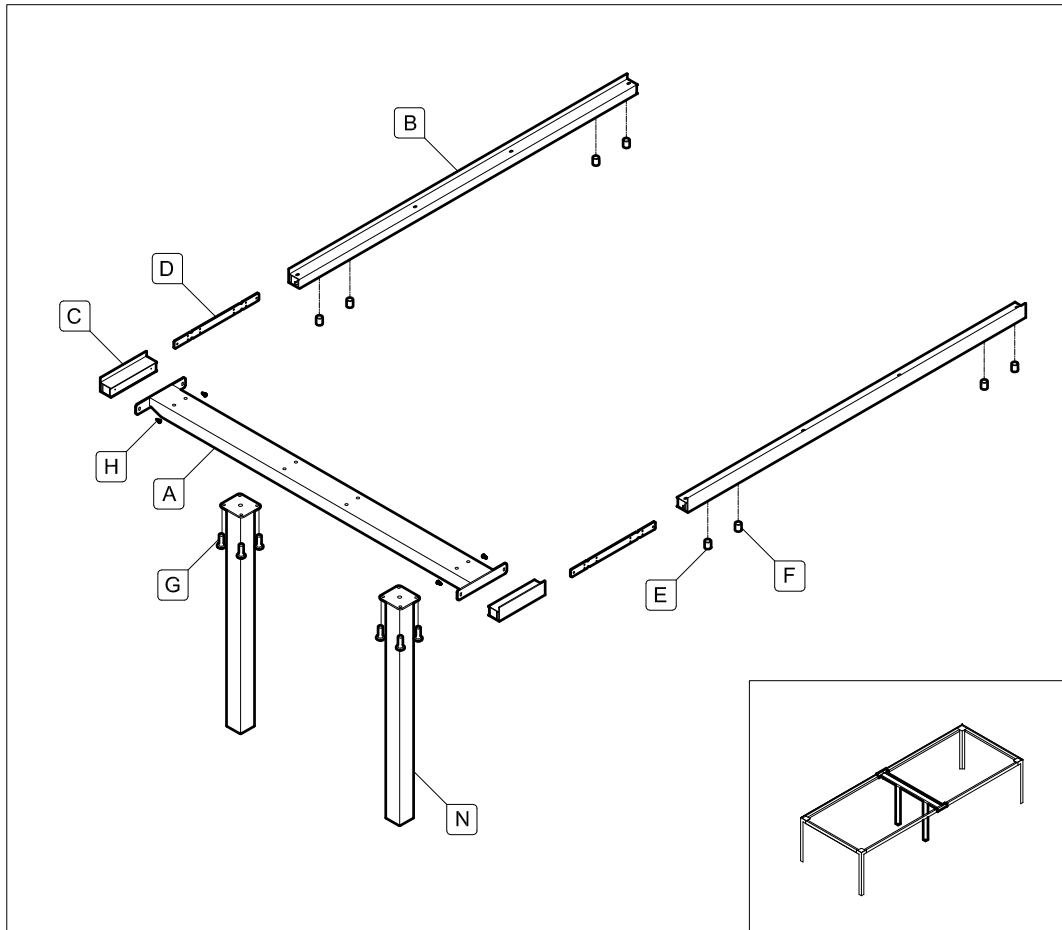
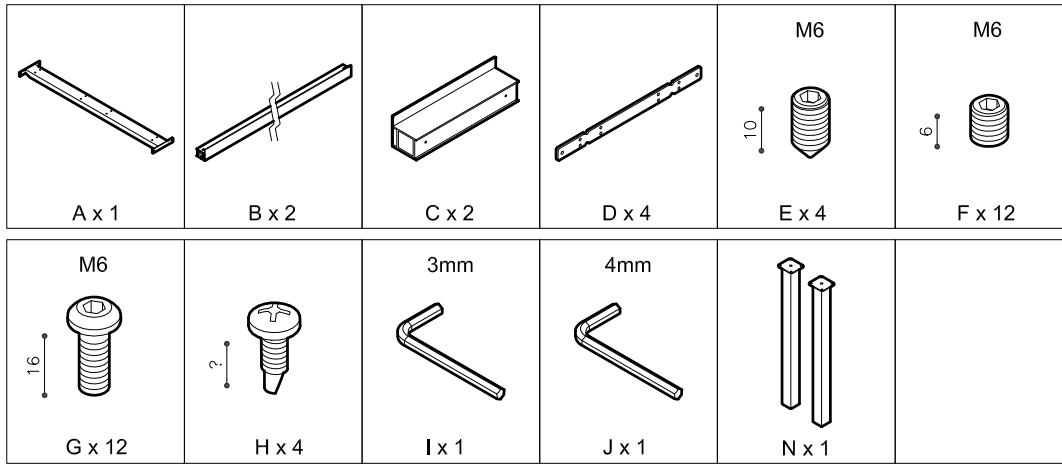
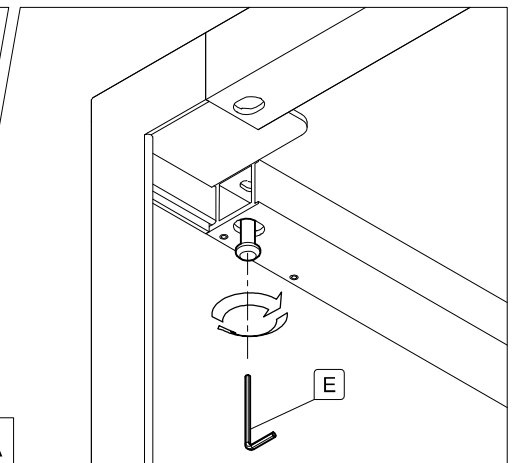
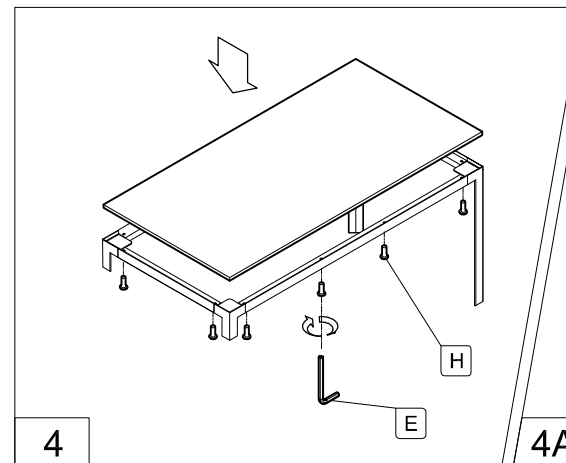
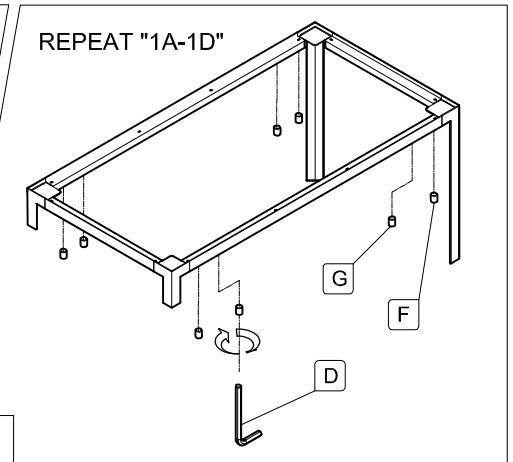
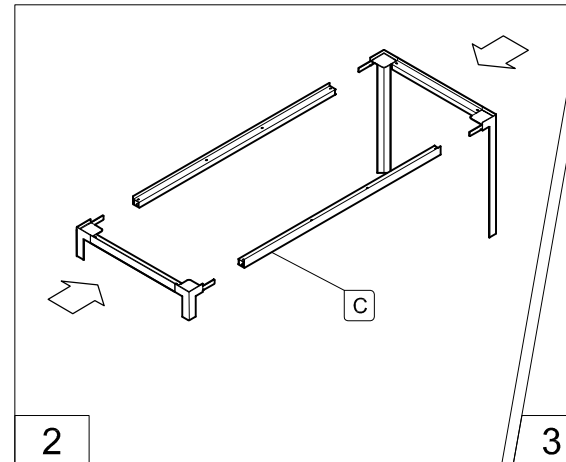
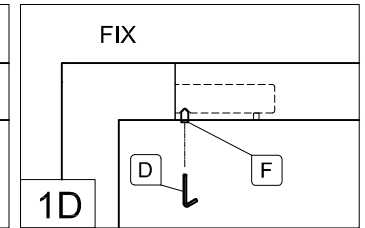
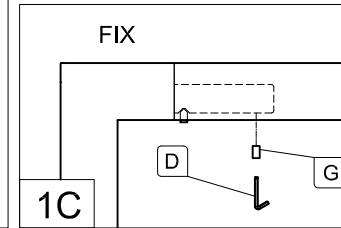
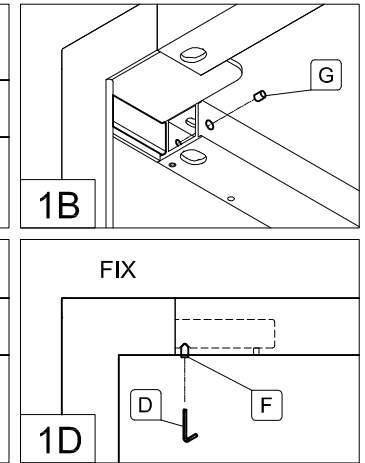
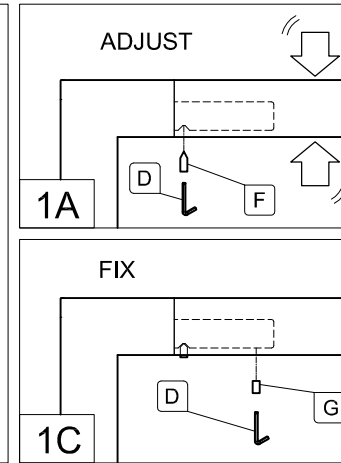
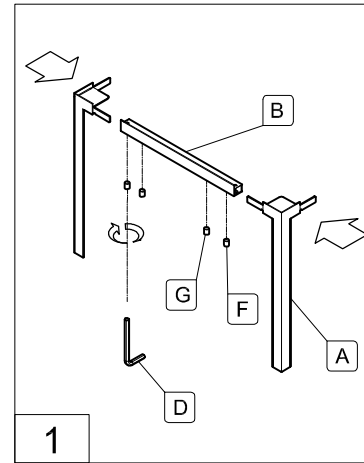
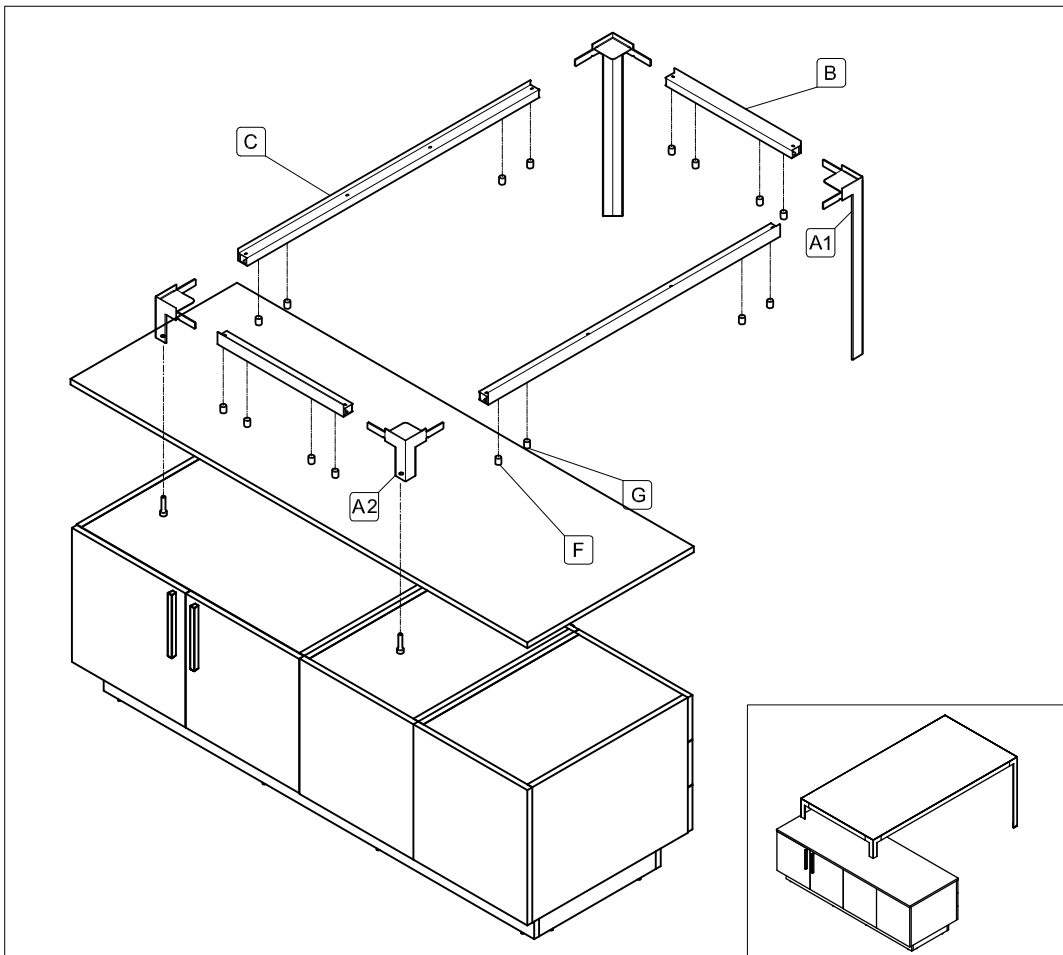
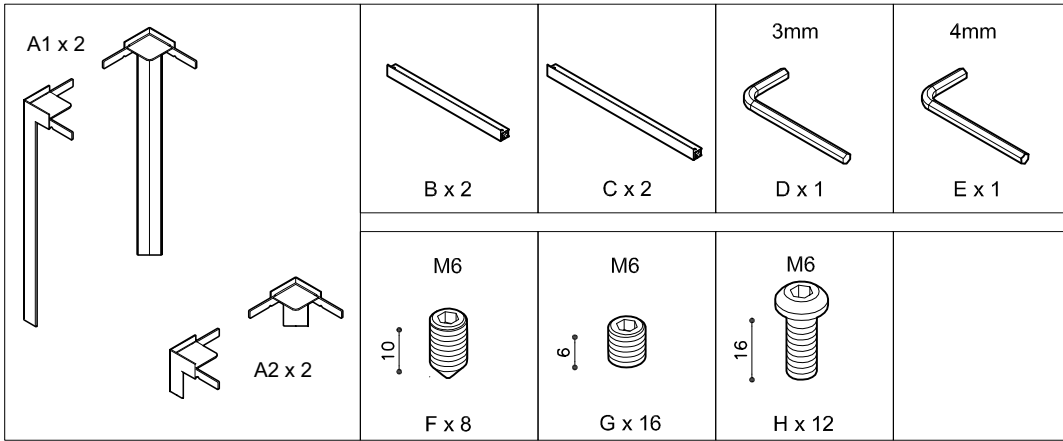

Ferramenta mobile piccolo:

- A - n° 12 Tirante 7x35
- B - n° 14 Spina legno
- C - n° 12 Barilotto 14x9
- D - n° 12 Grano 8x10
- E - n° 2 Cerniera collo 0
- F - n° 2 Base per cerniera
- G - n° 4 Vite autof. 3,5x15
- H - n° 1 Maniglia
- I - n° 2 Vite da 4x25
- L - n° 2 Copriforo da 5

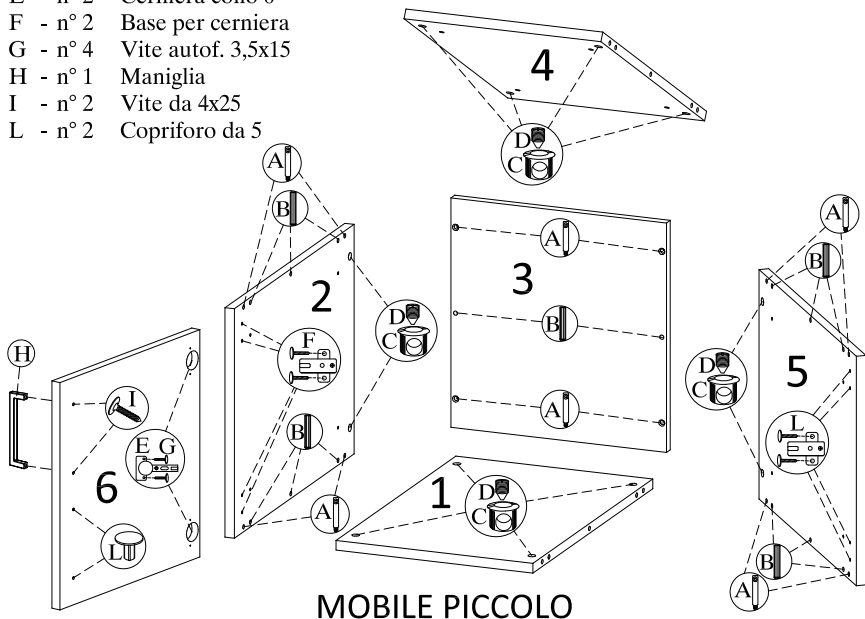

MOBILE PICCOLO

Ferramenta mobile grande:

- A - n° 12 Tirante 7x35
- B - n° 14 Spina legno
- C - n° 12 Barilotto 14x9
- D - n° 12 Grano 8x10
- E - n° 4 Cerniera collo 0
- F - n° 4 Base per cerniera
- G - n° 8 Vite autof. 3,5x15
- H - n° 2 Maniglia
- I - n° 4 Vite da 4x25
- L - n° 4 Copriforo da 5

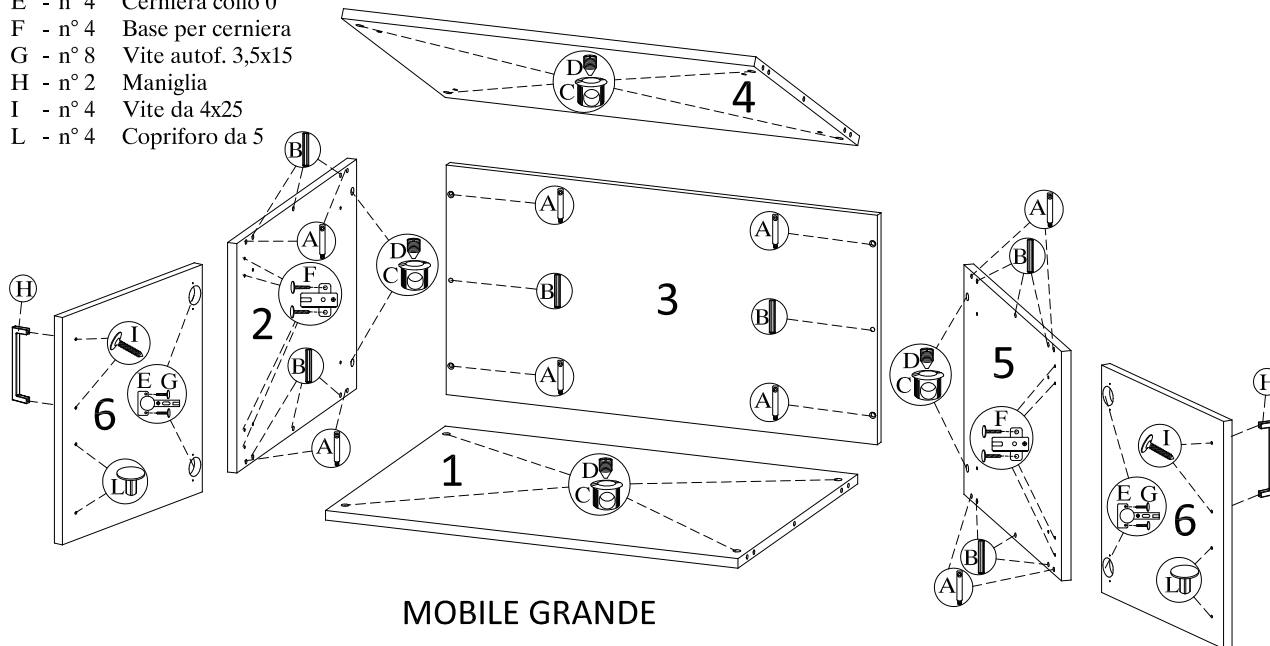

MOBILE GRANDE

ASSEMBLAGGIO

Ferramenta assemblaggio:

- M - n° 12 Vite 6MAX30 testa bombata
- N - n° 8 Vite 4x15
- O - n° 8 Tubetto di giunzione

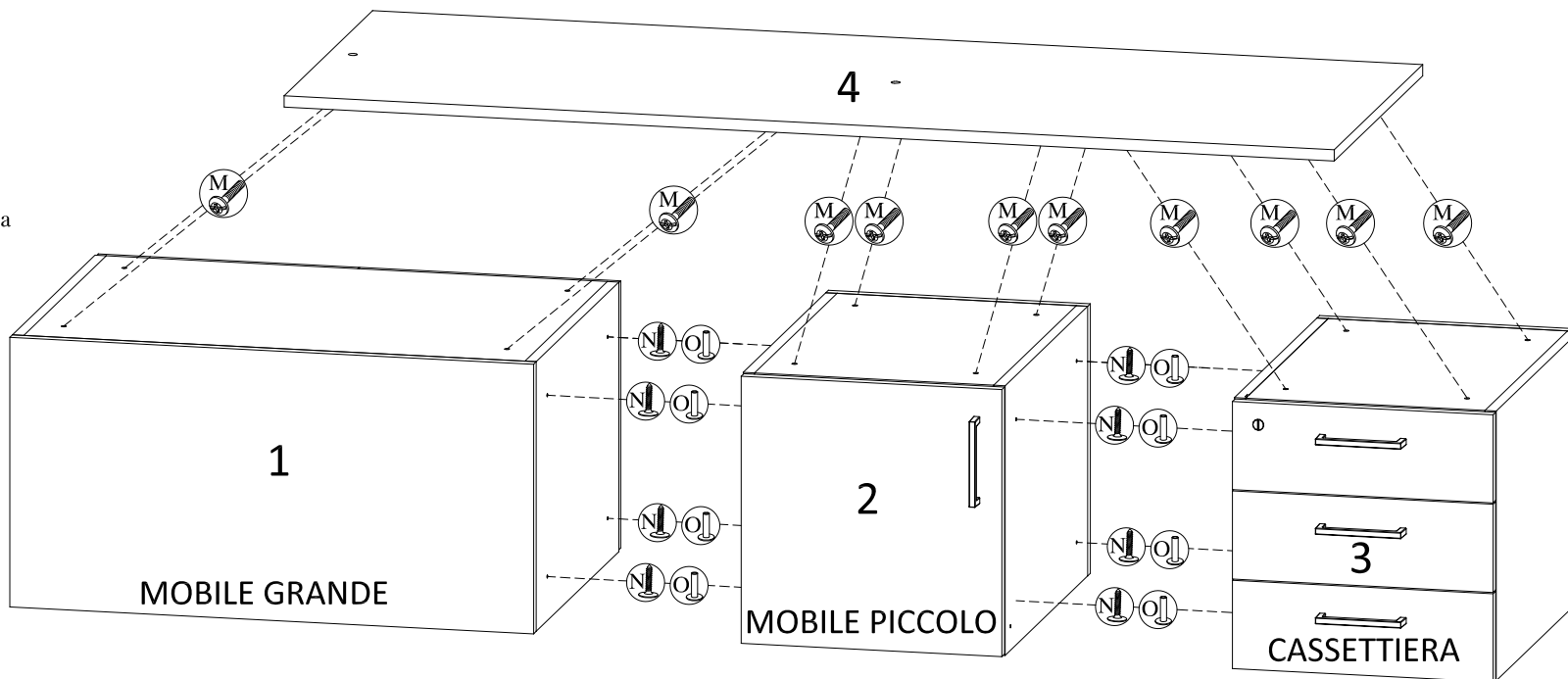

MOBILE GRANDE

MOBILE PICCOLO

CASSETTIERA

SCHEMA DI MONTAGGIO :

SERVENTE EOS/STRATOS ES139

Sequenza di montaggio numerata

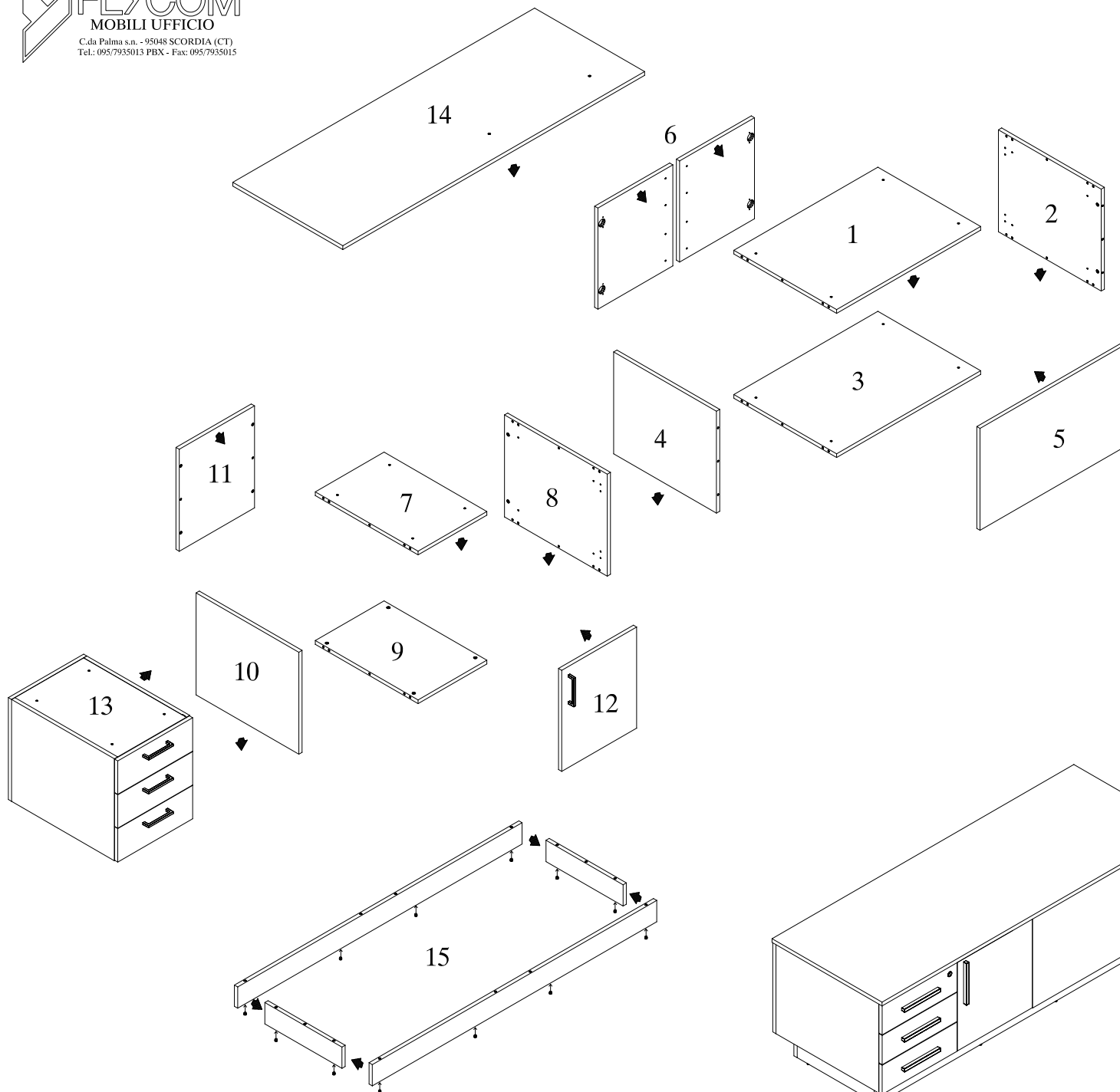

Ferramenta

- A  n. 44 BARILOTTI DA 14X9+GRANI
- B  n. 44 TIRANTI 7X35
- C  n. 34 SPINE LEGNO
- D  n. 12 VITI TBL 6MAX30 PER TOP
- E  n. 12 VITI AUTOFILETTATE 3,5X16 CERNIERE
- F  n. 6 MANIGLIE CON 12 VITI 4MAX25
- G  n. 6 BASETTE + 6 CERNIERE PER ANTA
- H  n. 12 PIEDINI

